

# 160 Series

## Protector Enclosure

For Indoor or  
Outdoor Applications

Molded of UL Listed  
Thermoplastic Material

Weather Resistant

Accepts All tii Maximum or  
Heavy Duty Total Failsafe®  
(TFS®) Protector Modules for  
1 or 2 Pair Protection

Easy Installation

Listed to UL 1863



160GS

160 Series Indoor/Outdoor Protector Enclosures shield Tii's Total Failsafe® (TFS®) Protector Modules or other electronic devices from most environmental conditions. It has a mounting base, a flexible grommet and a fitted flange cover that snaps tightly closed.

### KEY PRODUCT BENEFITS

- ▶ The 160GS is equipped with a ground stud and accepts one or two Maximum or Heavy Duty Total Failsafe® (TFS®) protector modules in a compact, secure enclosure
- ▶ Use these enclosures to house other listed electronic devices for a variety of indoor and outdoor applications or to protect wiring terminations
- ▶ The cover is molded of temperature and humidity-resistant thermoplastic, which resists cracking, crazing, and discoloration
- ▶ The cover interlocks with the base, protecting contents from corrosion, moisture, and debris
- ▶ For additional security, the cover can be secured with a cable tie or similar locking device
- ▶ The base, which is molded of the same durable thermoplastic material as the cover, includes a flexible grommet to accommodate the entry and exit of station drop wires and ground connections

### INDUSTRY STANDARDS

- ▶ Listed to UL 1863



**Tii Technologies Inc.**

**Corporate Headquarters:**

141 Rodeo Drive  
Edgewood, NY 11717  
Phone: 631.789.5000  
Fax: 631.789.5063  
Toll Free: 888.844.4720  
sales@tiitech.com

# 160 Series

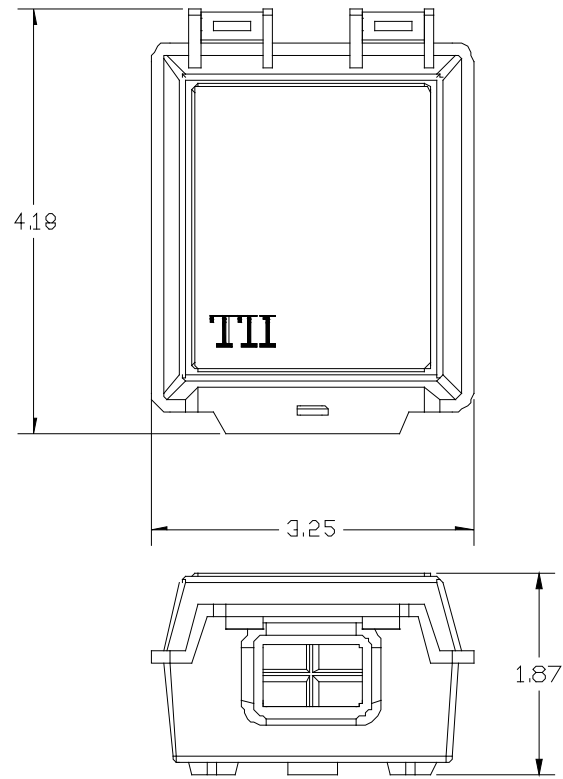

*Dimensions are in Inches*

## ORDERING INFORMATION

Model No.	Description
<b>160G</b>	Indoor/Outdoor Enclosure with Grommet
<b>160GS</b>	Indoor/Outdoor Enclosure with Grommet and Ground Stud